

ZOLLER

power shrink

The Modular Shrink Unit
for your Production



ZOLLER

expect great measures®

ZOLLER
expect great measures®

More Speed, Safer Processes, Greater Flexibility — »powerShrink«

How do you shrink-clamp and unclamp in record time? By using »powerShrink«. This inductive shrinking device for HSS and hard metal tools shortens setup times for your production processes. In less than 10 seconds, your tool will be heat-shrunk, cooled off in another 40 seconds, and then ready for production. Benefit from the high degree of rotation accuracy, long service life and reduced tool expenses.



Speed

- _ Shrink-clamping/Unclamping time: approx. 6 – 10 seconds (dependent on tool diameter)
- _ Cooling time: approx. 40 seconds (dependent on tool diameter)
- _ Time saving heating process

Safety

- _ High rotation accuracy, long service life
- _ Reliable process transfer of shrinking parameters from the presetter to the »powerShrink«

Flexibility

- All HM/HSS tools can be heat-shrunk
- _ Also suitable for tools with long shafts since the entire heating area is heated
- _ Modular design for individual adjustments, as needed

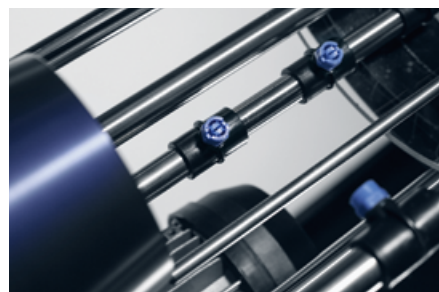
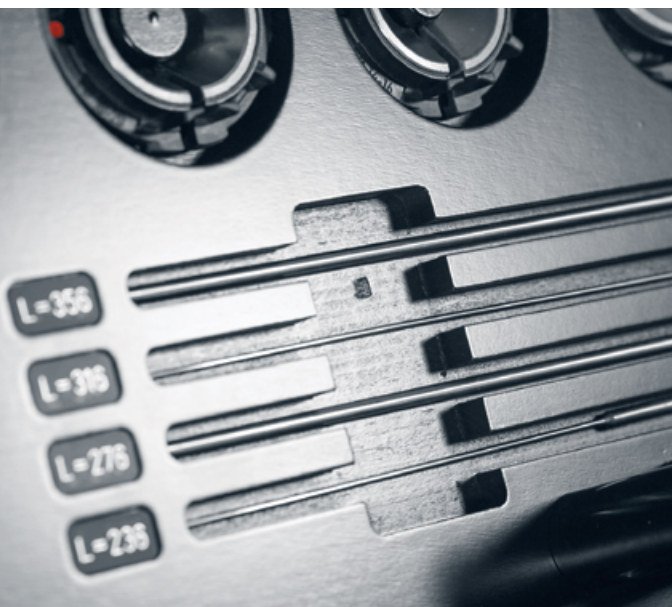

»powerShrink Basic« – the Standard shrinking device

- _ For all HM and HSS tools with a diameter of 3 – 32 mm
- _ With standard coils V2008 and interchangeable stop discs
- _ Single-location version
- _ Without integrated contact cooling



»powerShrink Economic« – the Entry-level Device

- _ For all HM and HSS tools with a diameter of 3 – 32 mm
- _ With standard coils V2008 and interchangeable stop discs
- _ Single-location version
- _ Also available with an adjustable coil



»powerShrink Economic Plus« – with Cooling

- _ For all HM and HSS tools with a diameter of 3 – 32 mm
- _ With standard coils V2008 and interchangeable stop discs
- _ Integrated contact cooling
- _ Single-location version
- _ Also available with an adjustable coil



»powerShrink Comfort« – with Cooling and Rotary Table

- _ For all HM and HSS tools with a diameter of 3 – 32 mm
- _ With standard coils V2008 and interchangeable stop discs
- _ Integrated contact cooling
- _ Rotary table with 3 stations
- _ Also available with an adjustable coil



Coils

Standard Coils V2008

Proven quality with interchangeable stop discs for heating all shrink fit chucks with a diameter of 3 to 32 mm. Five stop discs suffice for adjusting the coils to the respective feed dimension.



New Generation Coils

Flexible and practical. With just a single rotation, the length and diameter of the coil can be set to the dimensions of the shrink fit chuck.



Flue Gas Suction Device

Directly channels toxic gases into a filtration unit during shrinking process. This ensures safety for the operator without any additional effort.



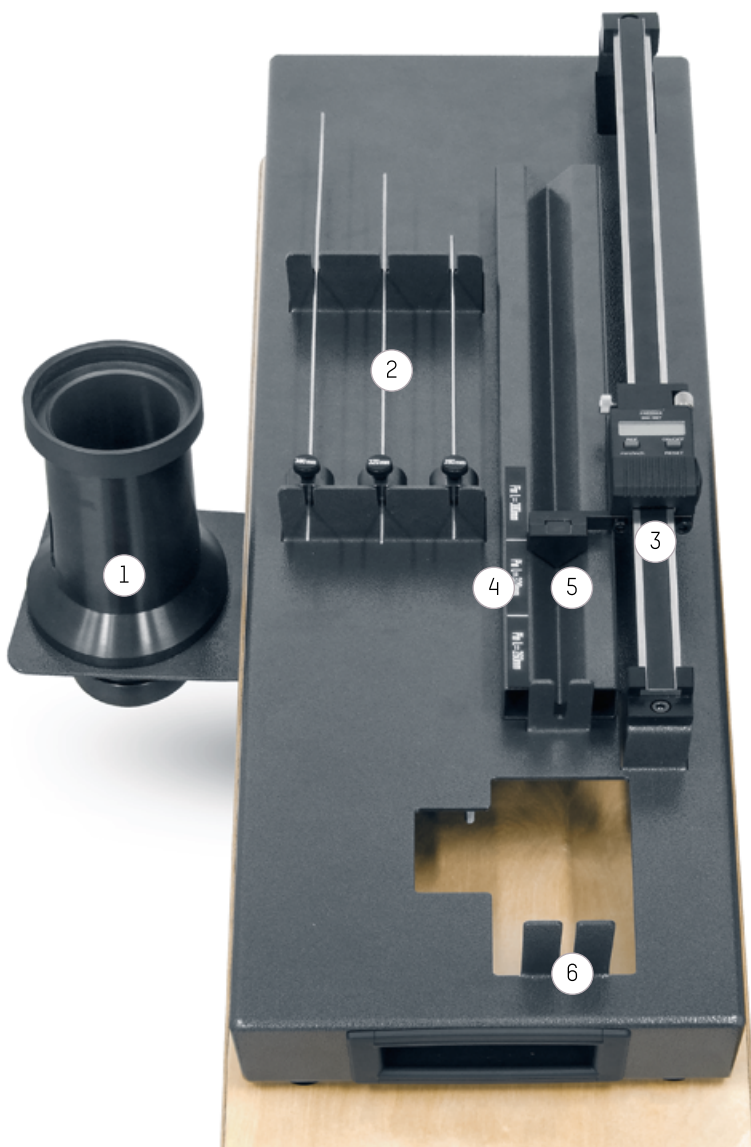

ZOLLER-»toolSet«

The optimal supplement for »powerShrink«. »toolSet« allows you to heat shrink your tools quickly, easily and precisely in accordance with the nominal length.

- 1 | Acquisition unit
- 2 | Setting pins
- 3 | Measuring system
- 4 | Pin selection scale
- 5 | Insertion prism
- 6 | Setting pin for stop surface

Set for Easy Length Presetting

- _ Quick and easy presetting of the tool projection lengths
- _ Max. projection length: 150 mm
- _ Precision: ± 0.05 mm
- _ Suitable for all shrink fit chuck and devices (flame, hot air, contact, induction)
- _ Space saving
- _ Excellent price-performance ratio
- _ Upgradeable at any time
- _ Scope of delivery with 3 clamp screws (Ø 3 – 12, Ø 12 – 20, Ø 16 – 25 mm) Optional: Ø 25 – 32 mm



Easy Set



Clamp screws

The Right Program for Safe Shrink-clamping and Unclamping

With the 293 heat shrinking program from the »pilot« software, you can transfer heat shrinking parameters for tools from any ZOLLER presetting and measuring machine to the »powerShrink«.

This guarantees the error-free shrink-clamping and unclamping of standard tools that can be performed by any operator.

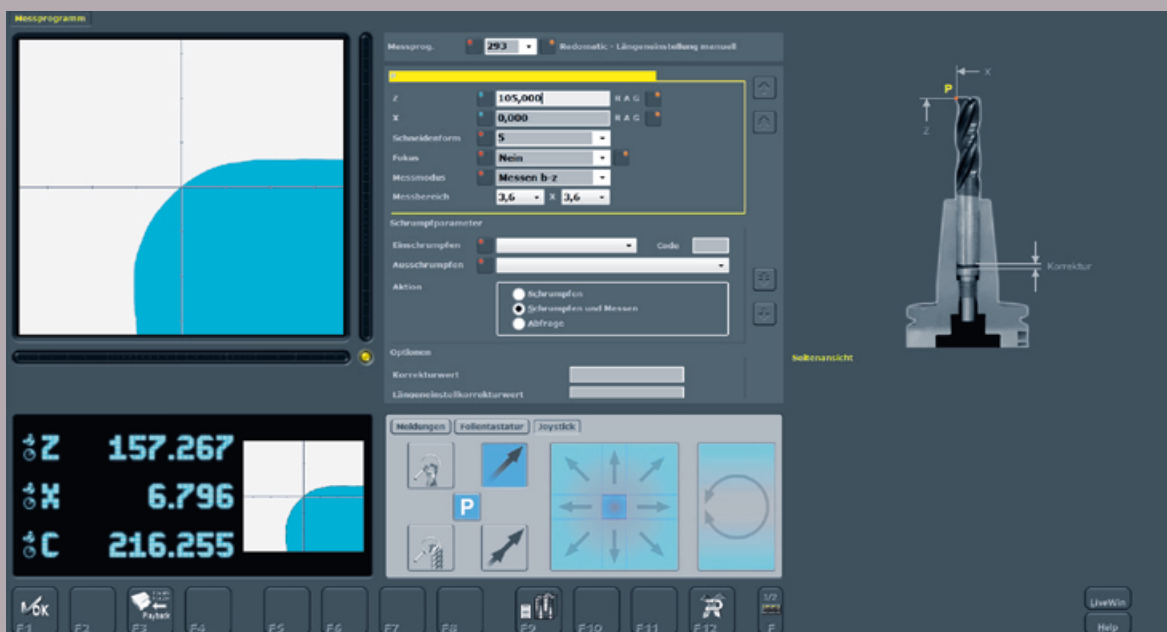

Input dialog for the 293 heat shrinking program in »pilot«.



01 Input of heat shrinking parameters and presetting the tool to the desired nominal length with the setting adapter.

02 Automatic transfer of heat shrink parameters to »powerShrink«



03 Heat shrinking the tool using the »powerShrink«, without manually selecting the parameters.



04 Tool can be re-measured and recorded, if needed.

Optionen



System Trolleys for a Well-organized Workplace

- _ Trolleys for heat shrinking machines and accessories
- _ Ergonomic working height
- _ Optional: Drawer insert for storing accessories



Shrink-clamping Device

- _ Unclamping assistance for broken milling tools
- _ Set with 1 basic holder and 6 ejectors (3 diameters in 2 lengths), without pliers



TME Intelligent Cooling System with Temperature Monitoring

- _ Measure feed temperature using sensors in the cooling elements
- _ Temperature display using a red or a green light
- _ Minimizing risk of injury
- _ Patented temperature monitoring



Cooling Adapter and Cooling Adapter Couplings

- _ Cooling adapter for all types of shrink fit chuck
- _ Cooling element with Ø 14–16 mm and Ø 25–32 mm with lateral lock

Technical Data

	Power [kW]	Connection	Max. Length of Shrink Fit Chuck [mm]	Dimensions [mm]	Weight [kg]	Tool Diameter [mm]
»powerShrink Basic«	10	3 x 400–480 volt, 16 ampere, 10 kVA	350	600 x 900 x 600	45	3 – 32
»powerShrink Economic«	13	3 x 400–480 volt, 16 ampere, 13 kVA	510/570*	860 x 970 x 500	50	3 – 32
»powerShrink Economic Plus«	13	3 x 400–480 volt, 16 ampere, 13 kVA	510/570*	860 x 970 x 650	70	3 – 32
»powerShrink Comfort«	13	3 x 400–480 volt, 16 ampere, 13 kVA	510/570*	860 x 970 x 650	70	3 – 32
»powerShrink Profi Plus«	20	3 x 360–500 volt, 32 ampere, 20 kVA	550	860 x 970 x 650	85	3 – 50
»powerShrink Nano«	13	3 x 400–480 volt, 16 ampere, 13 kVA	230	750 x 620 x 650	75	3 – 16

* with adjustable coil

ZOLLER

solutions

More speed, high quality, safer processes – ZOLLER system solutions allow you to achieve more from all aspects of production. To do so, we combine hardware, software and services for our customers to create optimal system solutions for presetting, measuring, inspection and management of tools. Everything from a single supplier. Everything for your success. Everything with ZOLLER solutions.

Outstanding service included: If you have any questions, please contact us at:
+49 7144 8970-137



ZOLLER Solutions

Presetting & Measuring
Tool Management
Inspection & Measuring
Automation